



Flexible and
Scalable Warehouses

KEZAD Logistics Park Phase 4 Expansion



مجموعة كيزاد
KEZAD GROUP

PART OF
AD PORTS GROUP

Welcome to KEZAD Logistics Park Phase 4 Expansion

Ready-to-Use Facilities with Flexible and Scalable Solutions

KEZAD Group is the UAE's largest provider of fully integrated economic zones, value-added business services and industrial real estate solutions. The Group is committed to creating competitive business ecosystems that encourage unprecedented growth. At KEZAD Logistics Park Phase 4 Expansion, businesses can choose pre-built units, including Flex Units, Standard Warehouses and Light Industrial Units, bringing them shorter lead time and lower capital investments.



Unit Sizes
from 395m²



Unit Status
Domestic
Economic Zone



Built-up Area
19,334m²

Creating Possibilities, Together

Easy Market Access

Located in KEZAD Ma'mourah, Area A, the strategic location of this phase of the development - between Abu Dhabi and Dubai - provides access to over 75% of UAE's population within a 90-minutes' drive along three major highways. These facilities also have direct access to Khalifa Port, one of the fastest growing major ports in the world.

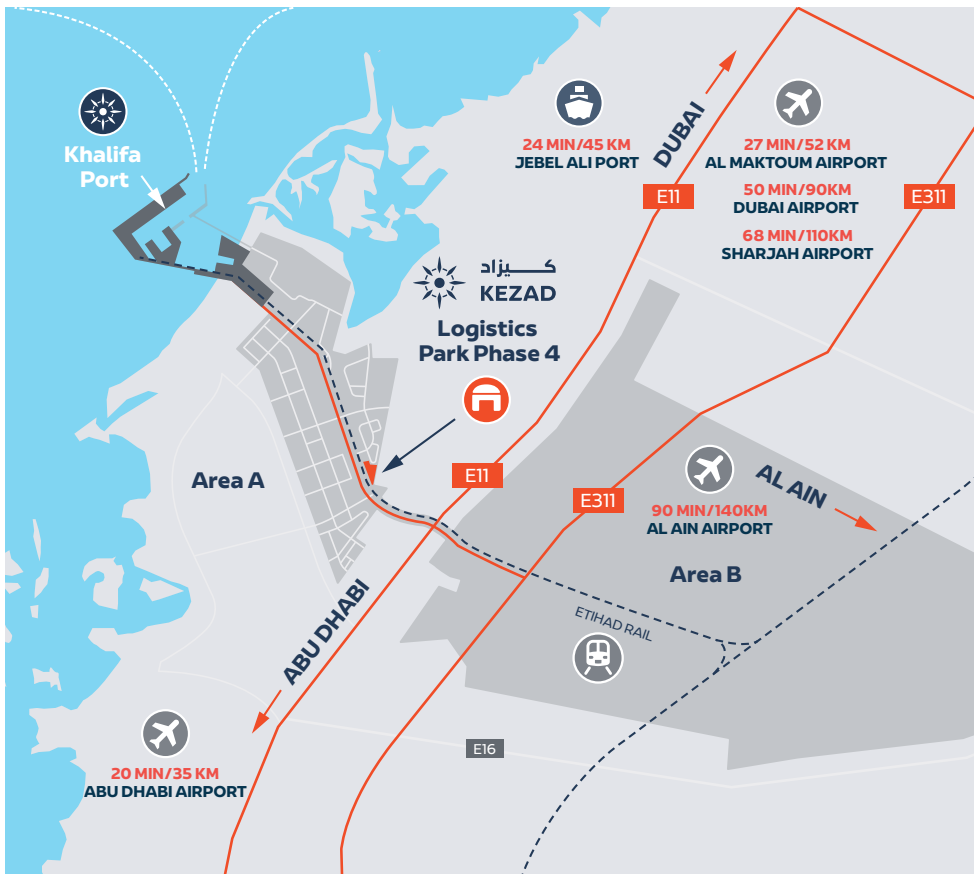

Site Plan

Designed to promote operational synergy and logistics efficiency



Flex Units



Specifications

Flex Units offer clients the opportunity to customise their units to suit their needs. These highly versatile units can be configured to provide them their desired blend of warehouse, showroom, training and demonstration areas. In addition, all Flex Units have a glass facade frontage providing excellent visibility onto the Khalifa Port highway.



Units from 607 m²
scalable to up to 5,939 m²



Two dock level loading
doors and one level access
per unit



50kN/m² floor loading
capacity/FM2 floor



Fire alarm and
sprinkler system



10m clear height



300W/m² power supply



1.3m raised floor level



Provision for toilets,
pantry and offices with
capped services (~10% of
the area)



Allocated parking in
each unit



Dock level door:
3m (W) x 3.25m (H)
Level access door:
3m (W) x 4.25m (H)

Flex Unit Exterior



Images are for illustrative purposes only. Actual facility may differ from the images shown.

Flex Unit Interior

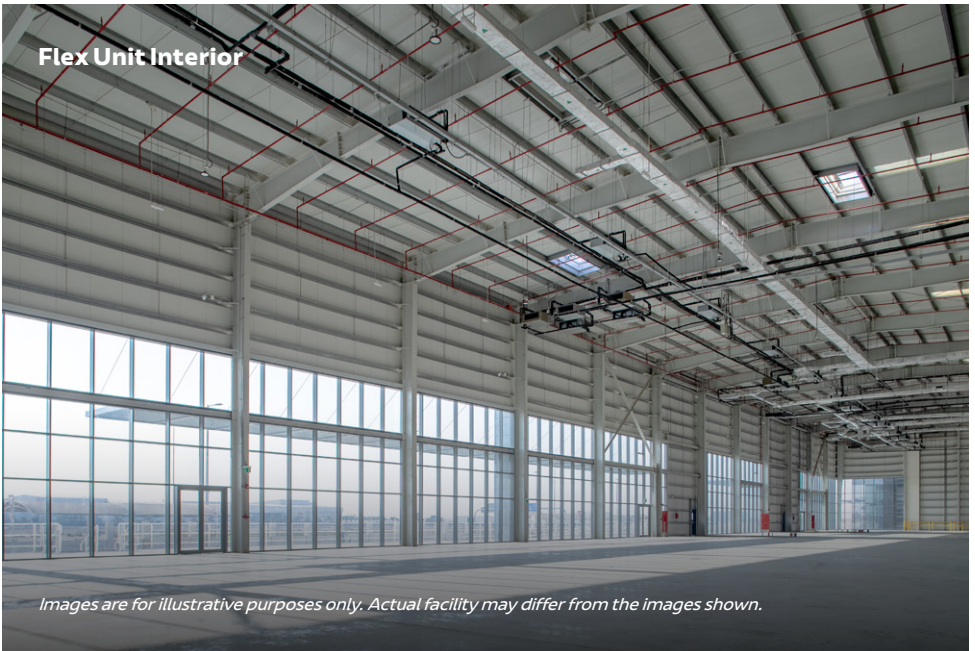

Images are for illustrative purposes only. Actual facility may differ from the images shown.

Flex Unit Layout

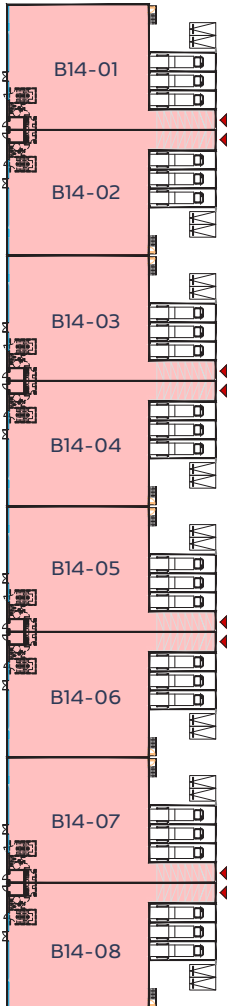

BLOCK (GSW-01)

TYPICAL FLEX UNIT
Total Area: 787sq.m.

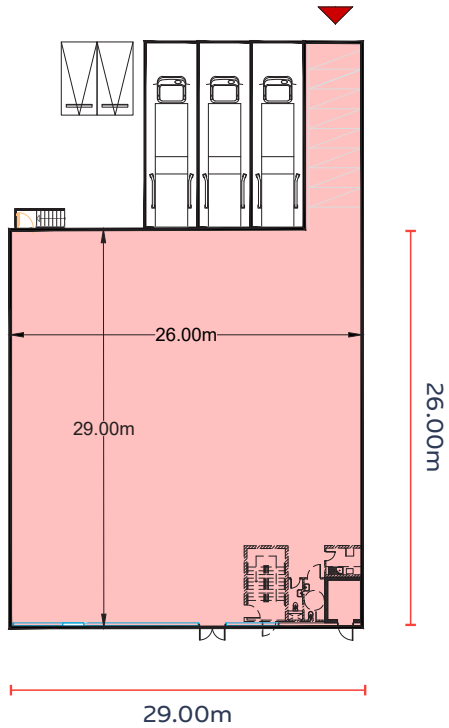

Standard Warehouses



Images are for illustrative purposes only. Actual facility may differ from the images shown.

Specifications

Our Standard Warehouses offer flexible space from 395m² and are ideal for storage, logistics and light industrial activities. Multiple units can be merged together side-by-side as well as in cross-docking configurations to create single units of up to 7,916m².



Units from 395m² with scalable combinations of up to 7,916m²



One dock level loading doors and one level access per unit



50kN/m² floor loading capacity/FM2 floor



Fire alarm and sprinkler system



8.5m clear height



185W/m² power supply



1.3m raised floor level



Provision for toilets, pantry, and offices with capped services (~10% of the area)



Allocated parking in each unit



Dock level door:
3m (W) x 3.25m (H)
Level access door:
3m (W) x 4.25m (H)



Standard Warehouse Layout

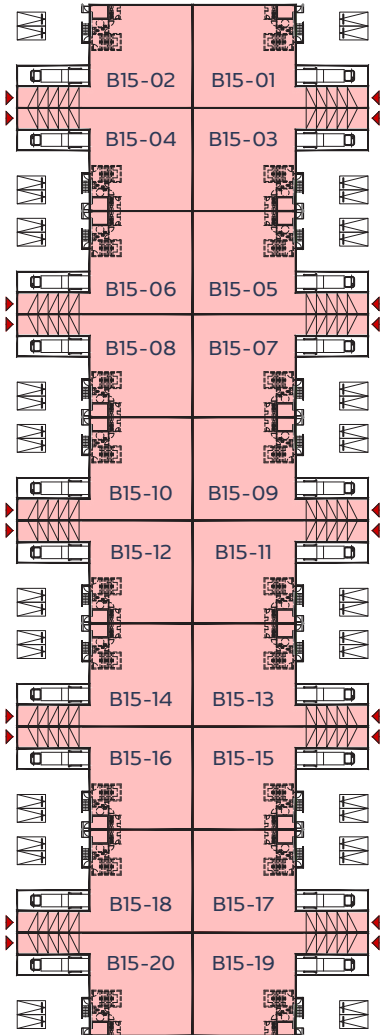

BLOCK (GSW-02)

TYPICAL STANDARD WAREHOUSE UNIT

Total Area: 396sq.m.

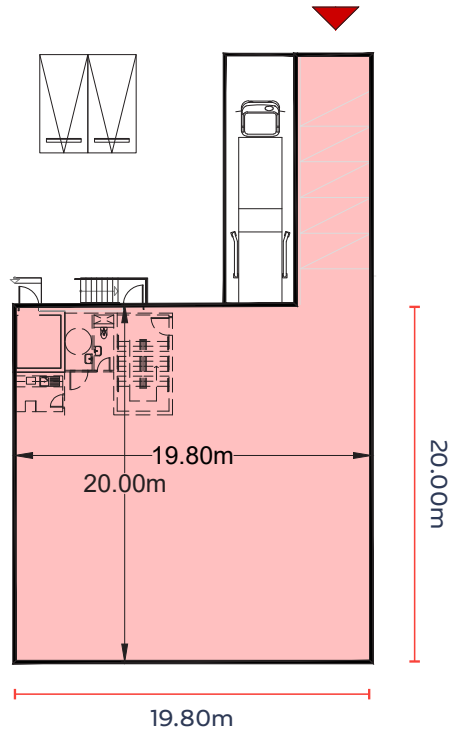

Light Industrial Units



Images are for illustrative purposes only. Actual facility may differ from the images shown.

Specifications

Light Industrial Units provide single spaces from 647m² that are perfect for an array of light industrial activities. Clients have the benefit of ground-level loading, increased power supply for machinery and installation of comfort cooling, as well as a 10.5m clear height with structural capability for installation of material handling equipment.



Units from 647m² with scalable combinations of up to 5,479m²



One ground level access door per unit



30kN/m² floor loading capacity/FM4 floor



Fire alarm and sprinkler system



10.5m clear height



300W/m² power supply



Level access door:
5m (W) x 5m (H)



Provision for toilets, pantry and offices with capped services (~10% of the area)

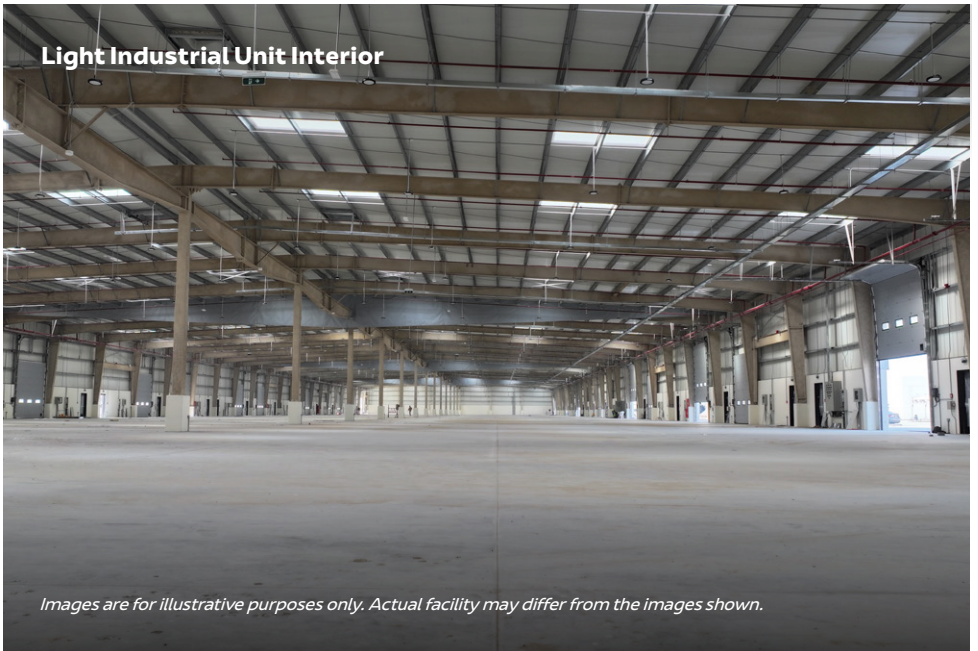

Light Industrial Units Layout

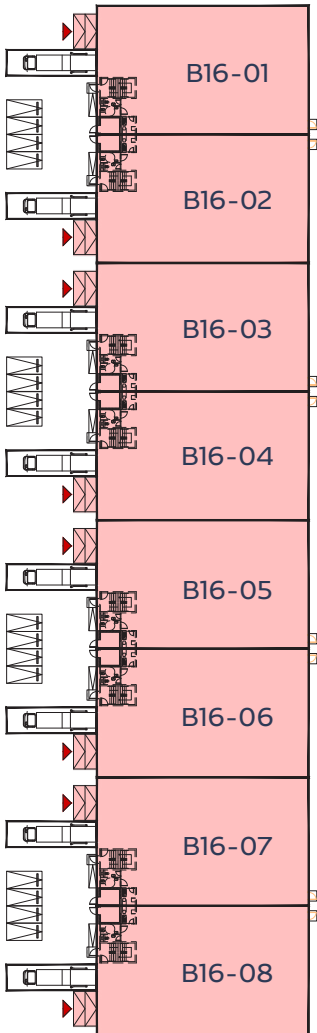

BLOCK (LIU-01)

TYPICAL LIGHT INDUSTRIAL UNIT

Total Area: 647sq.m.

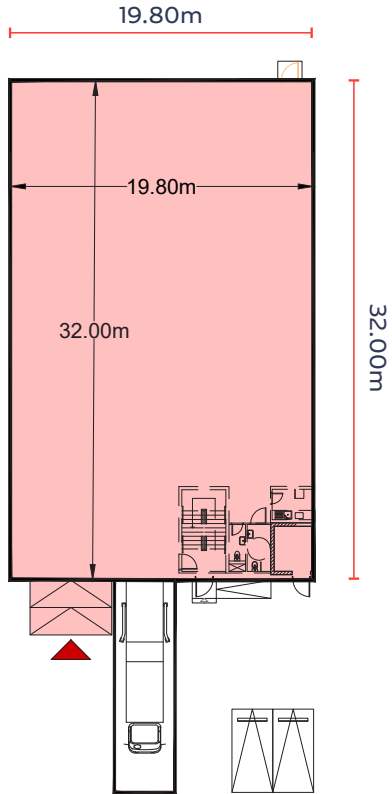

**At KEZAD Group,
We're Here to Listen,
Support and Deliver.**

Creating Possibilities, Together

**Scan the QR Code to Visit Our
Website to Find Out More**



+971 800 10 20 30

#MadeInKEZAD



enquiry@kezad.ae

@kezadgroup



kezadgroup.com

